

## DIMENSIONS

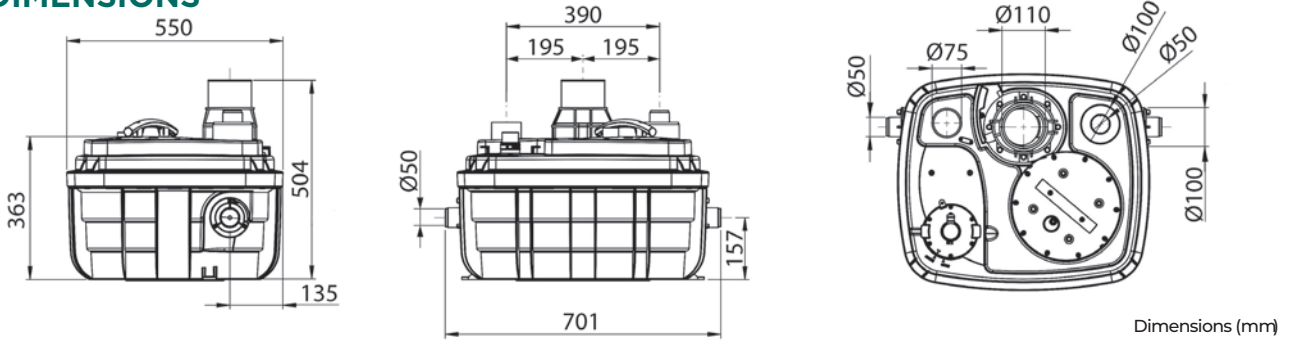

Dimensions (mm)

## CURVE

Discharge height (m)

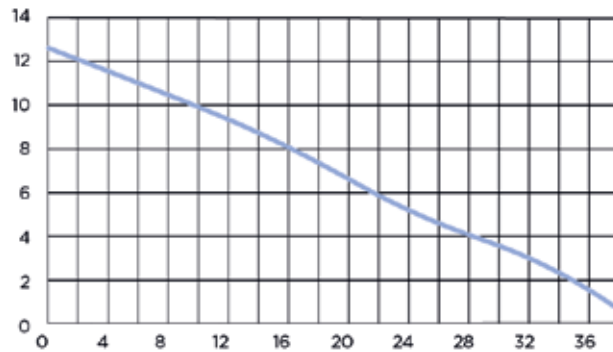

Flow rate (m<sup>3</sup>/h)

### Sanicubic 1 VX

Type of control box	Classic
Material	
Tank	PP GF
Pump housing	PA 12 GF
Motor housing	PA 12 GF
Impeller	PPO GF
Technical features	
Voltage (V)	230
Frequency (Hz)	50-60
Power consumption P1 (W)	2000
Power output P2 (W)	1400
Mode of operation	S3 15%
IP Rating	IP68
Hydraulics	
Total dynamic head (m)	13
Max. flow rate (m <sup>3</sup> /h)	40
External inlet diameter (mm)	40, 50, 100, 110, 125
Discharge diameter ext. (mm)	90/110
Ext. ventilation diameter (mm)	75
Total volume (L)	60
Useable volume (L)	21
ON Level /OFF level (mm)	165/95
Alarm level (mm)	235
Particle size (mm)	50
Max. temperature of the pumped liquid (5 min)	70 °C
Type of impeller	Vortex
Type of activation	Pneumatic
Identification and logistics	
Gross weight (kg)	30
Factory code	CUBIC1XLVX