

## DIMENSIONS

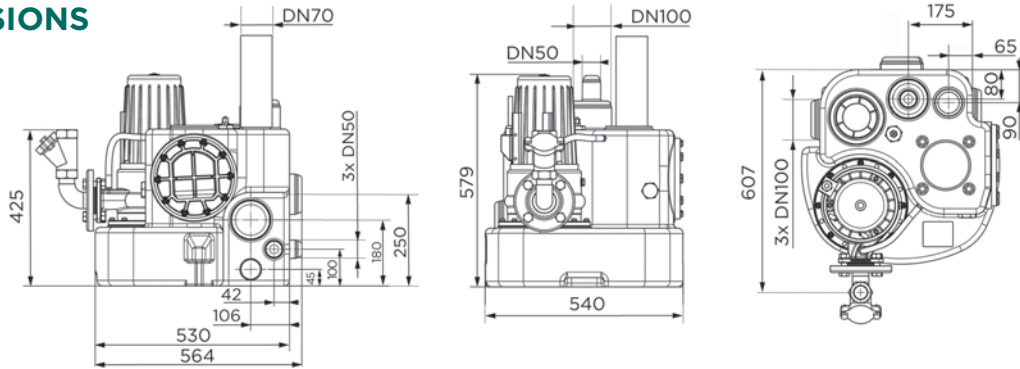

Dimensions (mm)

## CURVE

Discharge height (m)

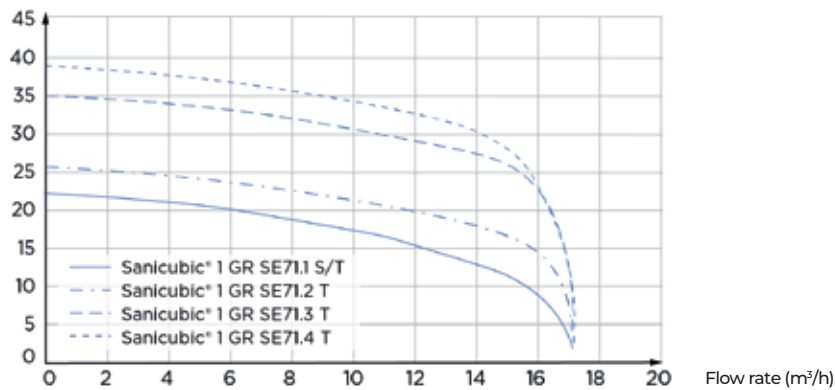

	Sanicubic 1 GR SE71.1 S	Sanicubic 1 GR SE71.1 T	Sanicubic 1 GR SE71.2 T	Sanicubic 1 GR SE71.3 T	Sanicubic 1 GR SE71.4 T
Type of control box	ZPS 1 case	ZPS 1 case	ZPS 1 case	ZPS 1 case	ZPS 1 case
Material					
Tank	PE LD	PE LD	PE LD	PE LD	PE LD
Pump housing	GG-20	GG-20	GG-20	GG-20	GG-20
Motor housing	GG-20	GG-20	GG-20	GG-20	GG-20
Impeller	GG-20	GG-20	GG-20	GG-20	GG-20
Technical features					
Voltage (V)	230	400	400	400	400
Frequency (Hz)	50-60	50-60	50-60	50-60	50-60
Power consumption P1 (W)	2200	2100	2100	3900	3900
Power output P2 (W)	1700	1700	1700	3200	3200
Mode of operation	S3 25%	S3 25%	S3 25%	S3 25%	S3 25%
IP Rating	IP68	IP68	IP68	IP68	IP68
Hydraulics					
Total dynamic head (m)	22	22	25	35	39
Max. flow rate (m <sup>3</sup> /h)	17	17	17	17	17
Inlet diameter DN	50, 100	50, 100	50, 100	50, 100	50, 100
Discharge diameter DN	50	50	50	50	50
Ext. ventilation diameter (mm)	75	75	75	75	75
Total volume (L)	55	55	55	55	55
ON Level /OFF level (mm)	140-250/30	140-250/30	140-250/30	140-250/30	140-250/30
Alarm level (mm)	180-290	180-290	180-290	180-290	180-290
Max. temperature of the pumped liquid (5 min)	55 °C	55 °C	55 °C	55 °C	55 °C
Type of impeller	Pro X K3 grinder	Pro X K3 grinder	Pro X K3 grinder	Pro X K3 grinder	Pro X K3 grinder
Type of activation	Pneumatic	Pneumatic	Pneumatic	Pneumatic	Pneumatic
Identification and logistics					
Gross weight (kg)	64	64	64	68	68
Factory code	CUBIC1GRSE71-1S	CUBIC1GRSE71-1T	CUBIC1GRSE71-2T	CUBIC1GRSE71-3T	CUBIC1GRSE71-4T