

Sanicubic 2 Classic

Grey water, black water

Sanicubic 2 Classic is a two pump lifting station designed for the lifting of wastewater. They benefit from the Pro X K2 maceration technology lifts / discharges waste water through a small 50 mm diameter ext. pipe. The two pumps work alternately. The 5 inlets, 2 of which are low, allow great flexibility in the installation of sanitary equipment.



PERFORMANCES

- Total dynamic head : 13 m
- Max. flow rate : 15 m³/h

PRODUCT BENEFITS

- Easily accessible with removable motors and level sensors for ease of maintenance.
- Alternating operation of the 2 pumps.
- 5 inlets, 2 of which are low-level.
- Low-level switching.
- Less chance of clogging due to the Pro X K2 grinder technology.
- Discharge in 50 mm ext. pipe.



BV Cert. 6045366



DELIVERED AS STANDARD

Classic control Box



Remote wired audible and visual alarm unit (5m)



CONNECTIONS

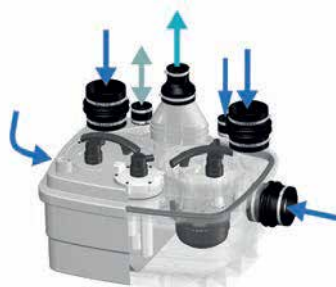

External inlet diameter : 40, 50, 100, 110 mm

Discharge diameter ext. : 50 mm

Ext. ventilation diameter : 50 mm



Pro X K2 grinder

DIMENSIONS

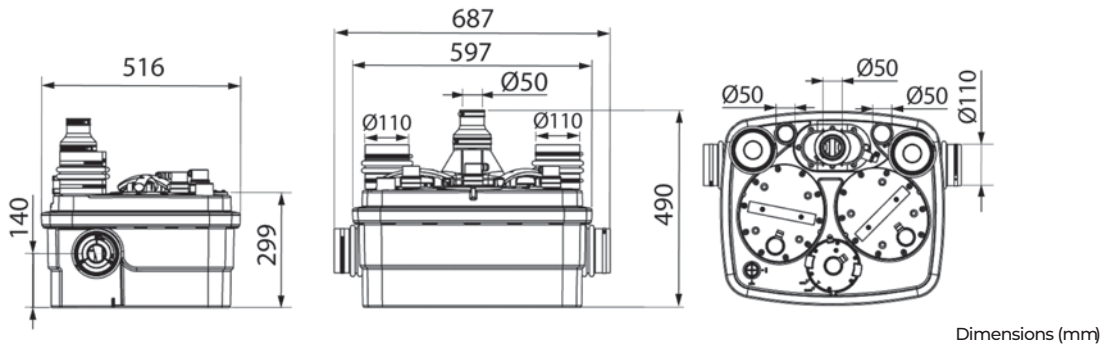

CURVE

Discharge height (m)

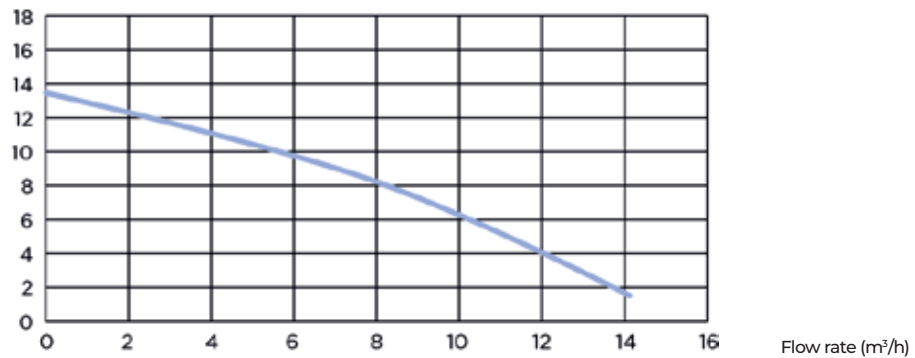

Sanicubic 2 Classic

Type of control box	Classic
Material	
Tank	PP
Pump housing	PA 12 GF
Motor housing	PA 12 GF
Impeller	PP GF
Technical features	
Voltage (V)	230
Frequency (Hz)	50-60
Power consumption P1 (W)	1500
Power output P2 (W)	1050
Mode of operation	S3 50%
IP Rating	IP68
Hydraulics	
Total dynamic head (m)	13
Max. flow rate (m ³ /h)	15
External inlet diameter (mm)	40, 50, 100, 110
Discharge diameter ext. (mm)	50
Ext. ventilation diameter (mm)	50
Total volume (L)	45
Useable volume (L)	17.5
ON Level/OFF level (mm)	140/70
Alarm level (mm)	210
Max. temperature of the pumped liquid (5 min)	70 °C
Type of impeller	Pro X K2 grinder
Type of activation	Pneumatic
Identification and logistics	
Gross weight (kg)	35
Factory code	R4LCIP68NM