

**GREASLY-4A-BASE**



Model **BASE** can be applied in areas where bad odour during maintenance is not causing any inconvenience. Access cover shall be opened for disposal of accumulated grease and solids extracted by a vacuum truck.





**Article description**

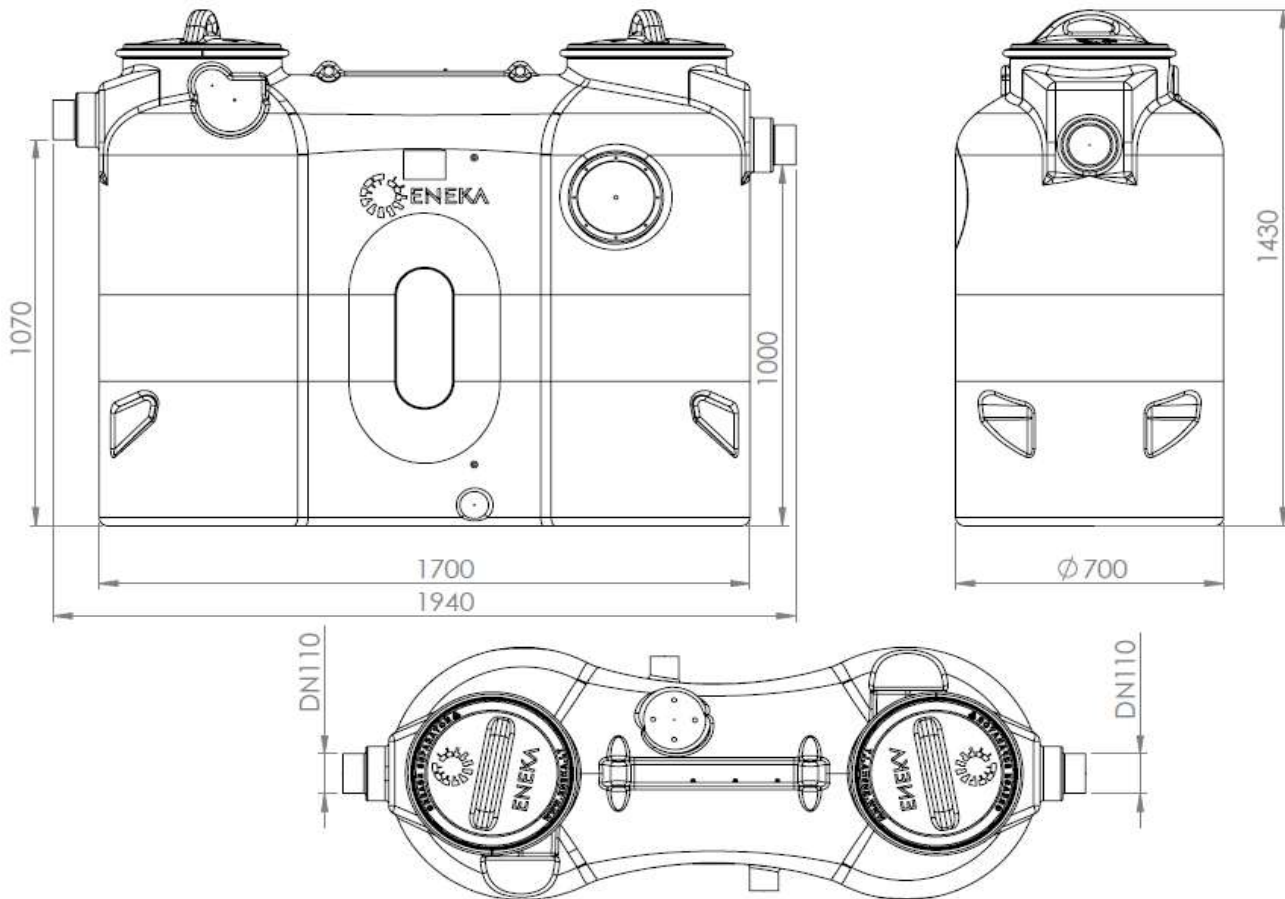



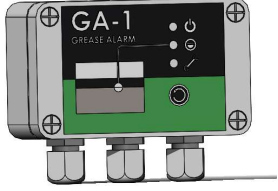

- Grease separators were developed to comply with DN1825 and DIN4040-100 standards.
- Grease separators made of polyethylene material which is durable, corrosion proof and chemically resistant
- Light weight
- Easy to transport
- For indoors installation – frost free
- With integrated sludge trap
- Cover with seal and steel locking ring
- Watertight / seamless one-piece body
- Sloped interior base for complete sludge disposal

Type	Flow rate, l/s	Sludge trap volume, l	Separator volume, l	Grease volume, l	Total volume, l	Weight, kg
Greasily-4A-BASE	4	400	450	160	850	91

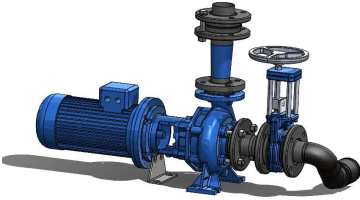

**Optional accessories**

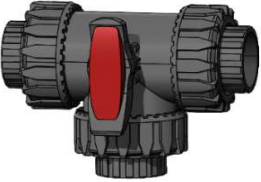
	<b>Name</b>	<b>Description</b>	<b>Item no.</b>
	Inspection window	Inspection window incl. wiper, stainless steel flange, seals, bolts	201-2100
	<b>Name</b>	<b>Description</b>	<b>Item no.</b>
	Extraction pipe NS2&NS4	Extraction pipe size DN65 incl. rubber coupling for odour free extraction	201-2200
	<b>Name</b>	<b>Description</b>	<b>Item no.</b>
	Manual reffiling unit NS2&NS4	Manual reffiling unit size DN20 incl. syphon & ball valve	201-2300
	<b>Name</b>	<b>Description</b>	<b>Item no.</b>
	Automatic reffiling unit NS2&NS4	Automatic reffiling unit size DN20 incl. syphon & ball valve	201-2390
	<b>Name</b>	<b>Description</b>	<b>Item no.</b>
	Mixer	Mixer with 2 stainless steel impellers for grease and sludge mixing. Motor 0,55 kW 400V 50/60 Hz	201-2400
	<b>Name</b>	<b>Description</b>	<b>Item no.</b>
	Grease alarm GA-1	Grease alarm type GA- 1 for grease detection	201-2500

	Name	Description	Item no.
	Disposal pump set DN65/50 NS2&NS4	Disposal pump set DN65/50. Motor 2,2 kW 400V 50/60 Hz, delivery head 9m.	201-2600
	Name	Description	Item no.
	Sampling chamber	Sampling chamber. ø400mm, lid with locking ring.	201-2800
	Name	Description	Item no.
	Automatic control panel	Automatic control panel with integrated alarm	201-2706
	Name	Description	Item no.
	Manual pump controller	Pump controller, manual incl. 3ph switch, phase sequence and thermal relays.	201-2707
	Name	Description	Item no.
	Mixer controller	Manual mixer controller incl. 3ph switch, phase sequence and thermal relays	201-2702
	Name	Description	Item no.
	Manual switchover valve mixing-disposal	Switchover valve: 3-way valve for switching between mixing and disposal.	201-2650
	Name	Description	Item no.
	Remote controller	Remote controller for automatic program-controlled emptying system.	201-2704