

GREASLY-2A-MIX

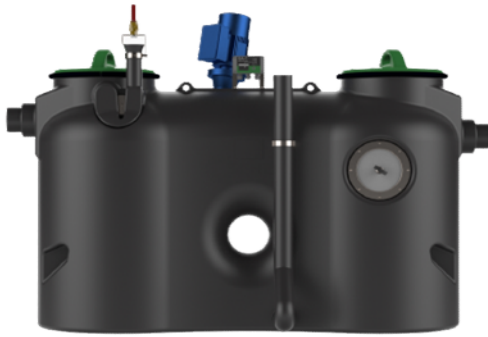

Model **MIX** is equipped with Grease alarm is indicating when the maximum level of accumulated grease is reached. Before emptying, Mixer actuated for blending grease, water and solid layers thus facilitating emptying of the separator. A special Extraction pipe is provided for the emptying of grease separator by the vacuum truck. After complete disposal, the separator is filled-up with freshwater.





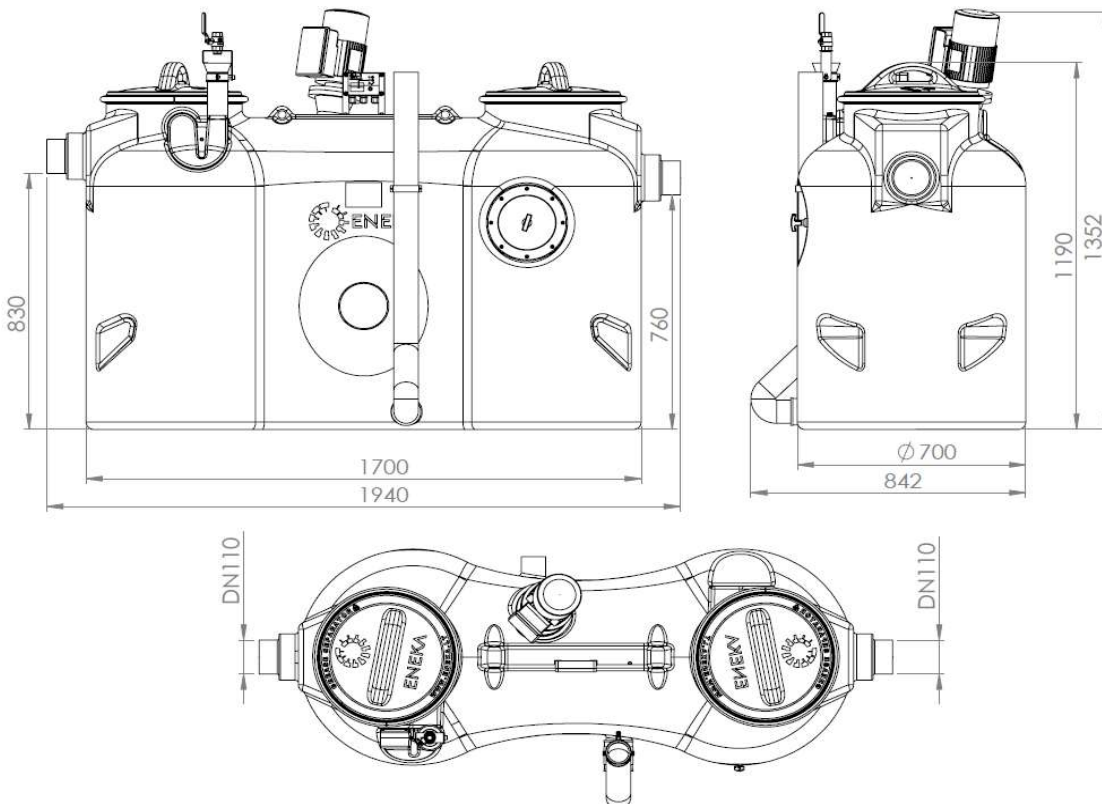

Article description

- Grease separators were developed to comply with DN1825 and DIN4040-100 standards.
- Grease separators made of polyethylene material which is durable, corrosion proof and chemically resistant
- Light weight
- Easy to transport
- For indoors installation – frost free
- With integrated sludge trap
- Mixer with 2x stainless steel impellers for grease& sludge, motor 0,55kW 400V 50/60Hz
- Cover with seal and steel locking ring
- Watertight / seamless one-piece body
- Sloped interior base for complete sludge disposal
- Inspection window incl. wiper, stainless steel flange, seals
- Grease alarm type GA-1
- Manual Refilling Unit size DN20, incl. syphon & ball valve
- Mixer Controller incl. 3ph switch, phase sequence& thermal relays



Type	Flow rate, l/s	Sludge trap volume, l	Separator volume, l	Grease volume, l	Total volume, l	Weight, kg
Greasly-2A-MIX	2	200	450	80	650	119

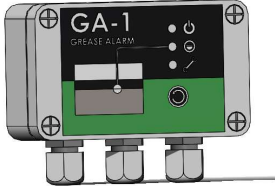

Standard accessories

	Name	Description	Item no.
	Inspection window	Inspection window incl. wiper, stainless steel flange, seals, bolts	201-2100
	Name	Description	Item no.
	Extraction pipe NS2&NS4	Extraction pipe size DN65 incl. rubber coupling for odour free extraction	201-2200
	Name	Description	Item no.
	Manual refilling unit NS2&NS4	Manual refilling unit size DN20 incl. syphon & ball valve	201-2300
	Name	Description	Item no.
	Mixer	Mixer with 2 stainless steel impellers for grease and sludge mixing. Motor 0,55 kW 400V 50/60 Hz	201-2400
	Name	Description	Item no.
	Grease alarm GA-1	Grease alarm type GA- 1 for grease detection	201-2500
	Name	Description	Item no.
	Mixer controller	Manual mixer controller incl. 3ph switch, phase sequence and thermal relays	201-2702

Optional accessories

	Name	Description	Item no.
	Disposal pump set DN65/50 NS2&NS4	Disposal pump set DN65/50. Motor 2,2 kW 400V 50/60 Hz, delivery head 9m.	201-2600
	Name	Description	Item no.
	Sampling chamber	Sampling chamber. ø400mm, lid with locking ring.	201-2800
	Name	Description	Item no.
	Automatic control panel	Automatic control panel with integrated alarm	201-2706
	Name	Description	Item no.
	Manual pump controller	Pump controller, manual incl. 3ph switch, phase sequence and thermal relays.	201-2707
	Name	Description	Item no.
	Automatic refilling unit NS2&NS4	Automatic refilling unit size DN20 incl. syphon & ball valve	201-2390
	Name	Description	Item no.
	Manual switchover valve mixing-disposal	Switchover valve: 3-way valve for switching between mixing and disposal.	201-2650
	Name	Description	Item no.
	Remote controller	Remote controller for automatic program-controlled emptying system.	201-2704