

GREASLY-15A-MIX



Model **MIX** is equipped with Grease alarm is indicating when the maximum level of accumulated grease is reached. Before emptying, Mixer actuated for blending grease, water and solid layers thus facilitating emptying of the separator. A special Extraction pipe is provided for the emptying of grease separator by the vacuum truck. After complete disposal, the separator is filled-up with freshwater.





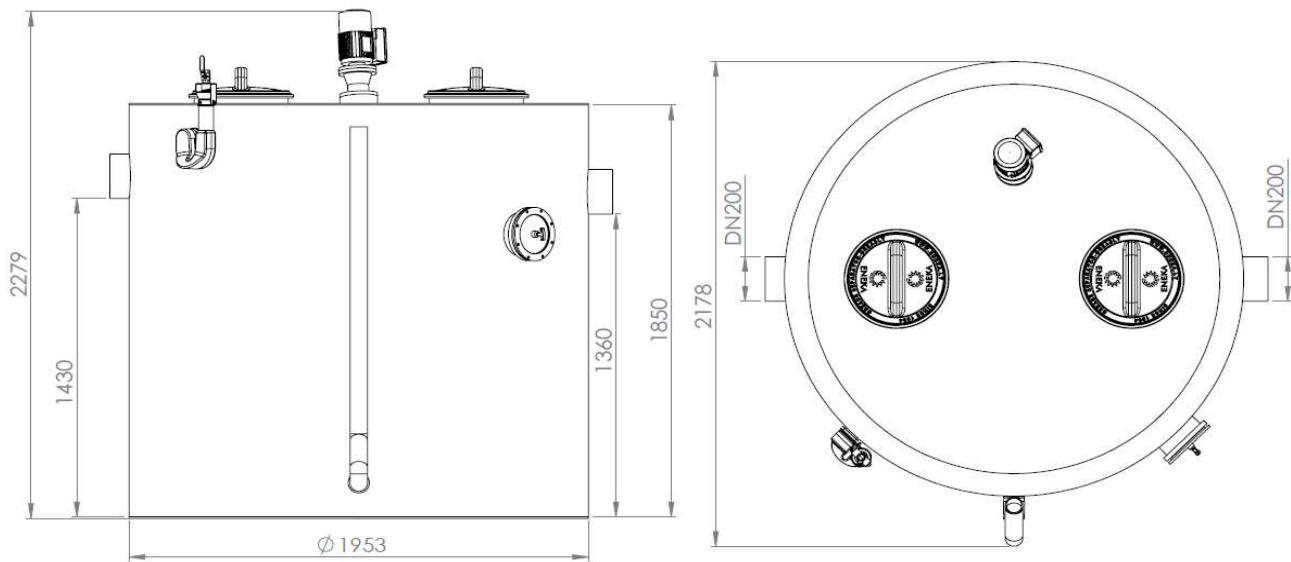

Article description

- Grease separators were developed to comply with DN1825 and DIN4040-100 standards.
- Grease separators made of polyethylene material which is durable, corrosion proof and chemically resistant
- Light weight
- Easy to transport
- For indoors installation – frost free
- With integrated sludge trap
- Mixer with 2x stainless steel impellers for grease&sludge, motor 0,55kW 400V 50/60Hz
- Cover with seal and steel locking ring
- Watertight / seamless one-piece body
- Sloped interior base for complete sludge disposal
- Inspection window incl. wiper, stainless steel flange, seals
- Grease alarm type GA-1
- Manual Refilling Unit size DN25, incl. syphon & ball valve
- Mixer Controller incl. 3ph switch, phase sequence&thermal relays





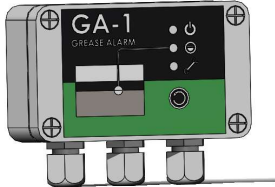

Type	Flow rate, l/s	Sludge trap volume, l	Separator volume, l	Grease volume, l	Total volume, l	Weight, kg
Greasly-15A-MIX	15	1500	1800	600	3300	441

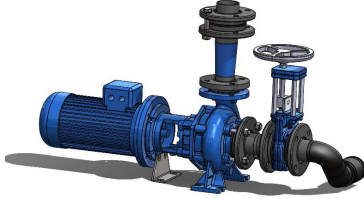
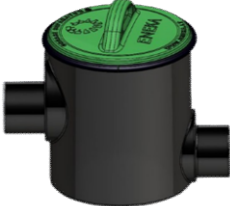

Standard accessories

	Name	Description	Item no.
	Inspection window	Inspection window incl. wiper, stainless steel flange, seals, bolts	201-2100
	Name	Description	Item no.
	Extraction pipe NS7/10/15	Extraction pipe size DN80/65 incl. rubber coupling for odour free extraction	201-2220
	Name	Description	Item no.
	Manual refilling unit NS7/10/15	Manual refilling unit size DN25 incl. syphon & ball valve	201-2320
	Name	Description	Item no.
	Mixer	Mixer with 2 stainless steel impellers for grease and sludge mixing. Motor 0,55 kW 400V 50/60 Hz	201-2400
	Name	Description	Item no.
	Grease alarm GA-1	Grease alarm type GA- 1 for grease detection	201-2500
	Name	Description	Item no.
	Mixer controller	Manual mixer controller incl. 3ph switch, phase sequence and thermal relays	201-2702

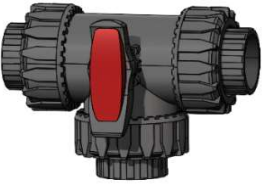
Optional accessories

	Name	Description	Item no.
	Disposal pump set DN80/65 NS7/10/15	Disposal pump set DN80/65. Motor 3kW 400V 50/60 Hz, delivery head 10m..	201-2620
	Sampling chamber	Sampling chamber. ø400mm, lid with locking ring.	201-2800
	Automatic control panel	Automatic control panel with integrated alarm	201-2706
	Manual pump controller	Pump controller, manual incl. 3ph switch, phase sequence and thermal relays.	201-2707
	Automatic refilling unit NS7/10/15	Automatic refilling unit size DN25 incl. syphon & ball valve	201-2380
	Manual switchover valve mixing-disposal	Switchover valve: 3-way valve for switching between mixing and disposal.	201-2650
	Remote controller	Remote controller for automatic program-controlled emptying system.	201-2704