

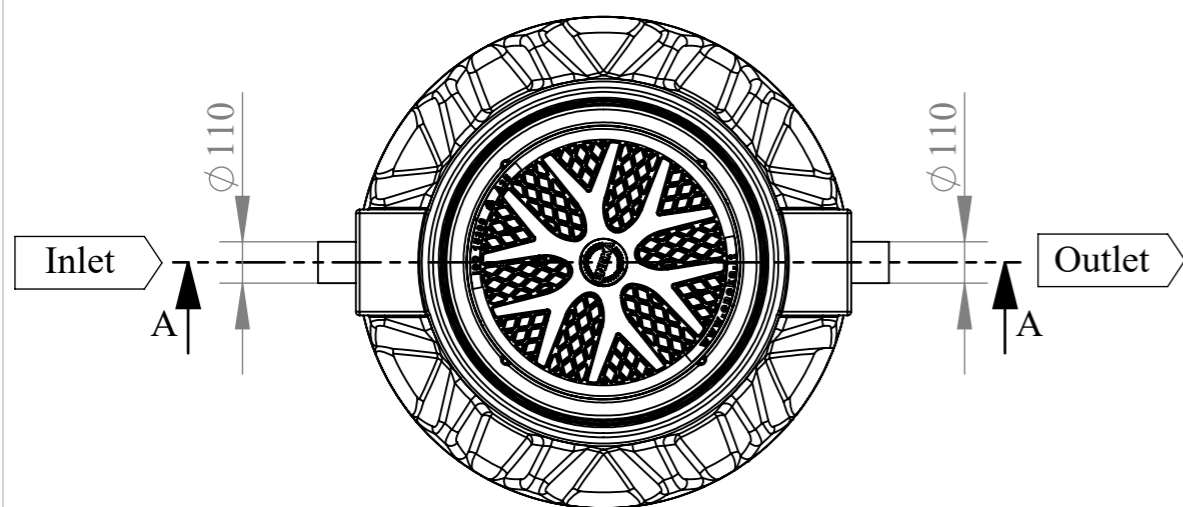

A-A



		Class	Weight
1	Cover according to standard EN124 (☒)	A35 (3,5 t) □	13 kg
		B125 (12,5 t) □	45 kg
		C250 (25 t) □	55 kg
		D400 (40 t) □	90 kg
2	Maintenance shaft (☒)	800...1000 □	31 kg
		1000...1250 □	33 kg
		1250...1500 □	42 kg
		1500...1750 □	52 kg
		1750...2000 □	62 kg
		2000...2250 □	71 kg
		2250...2500 □	80 kg
3	Ladder		
4	Storage capacity for grease	80 l	
5	Grease separation chamber	550 l	
6	Sludge trap	200 l	
7	Grease level alarm sensor (☒)	□	
		Nominal flow rate	2 l/s
		Total capacity	750 l
Weight excluding manhole shaft/lid		80 kg	S
		120 kg	R

Product	GR	Name	Grease separator Greasly 2 B		Scale	1:20	
Design by	V.Laucius	Checked by	E.Mozuraitis	Approved by	E.Kuodis	Drawing type Customer drawing	
 <b>UAB ENEKA</b> Vandziogalos g. 94 LT-47467 Kaunas, Lithuania tel. +37037377441, faks. +37037377907 www.eneka.lt, info@eneka.lt			Construction site	-		Drawing no. -	
Date	4/22/2020	Lang.	en	Sheet	1		