

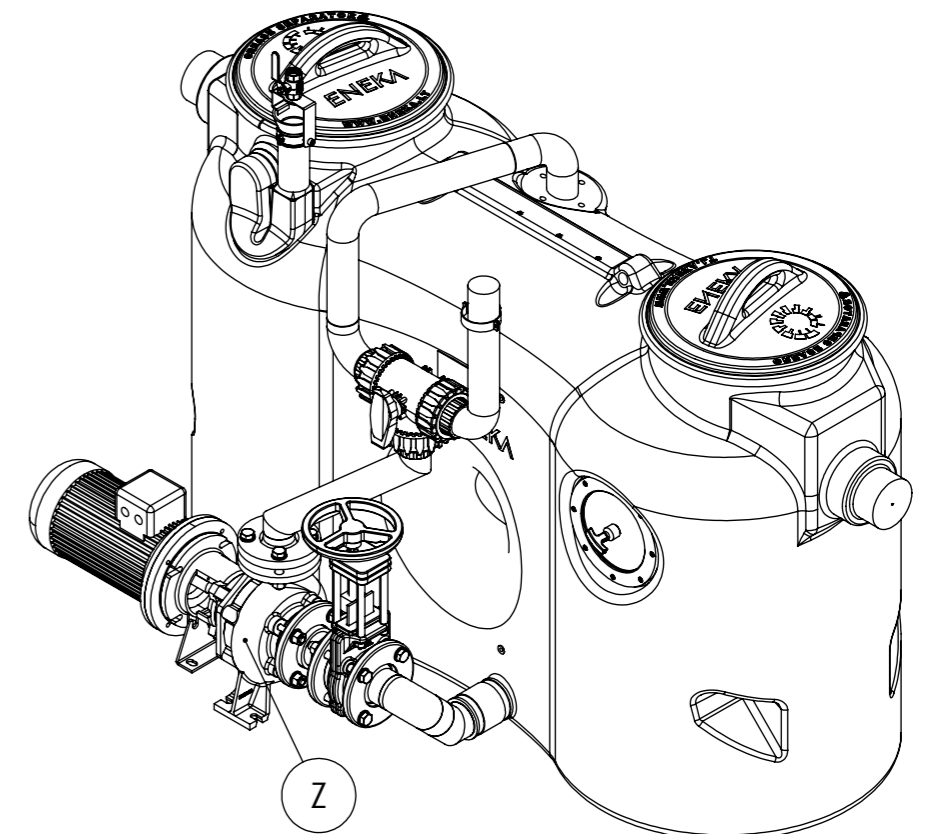

Position	Name	Quantity
A	Greasly 2A body	1
B	Lid with locking ring and gasket	2
C	Inspection window	1
E	Manual wather filling unit	1
Z	Disposal pump and mixing unit	1
	Greasly 4A Pump technical characteristics	
	Flow rate	2 l/s
	Total volume	650 L
	Grease volume	80 L
	Separator volume	450 L
	Sludge trap volume	200 L
	Weight	158 kg

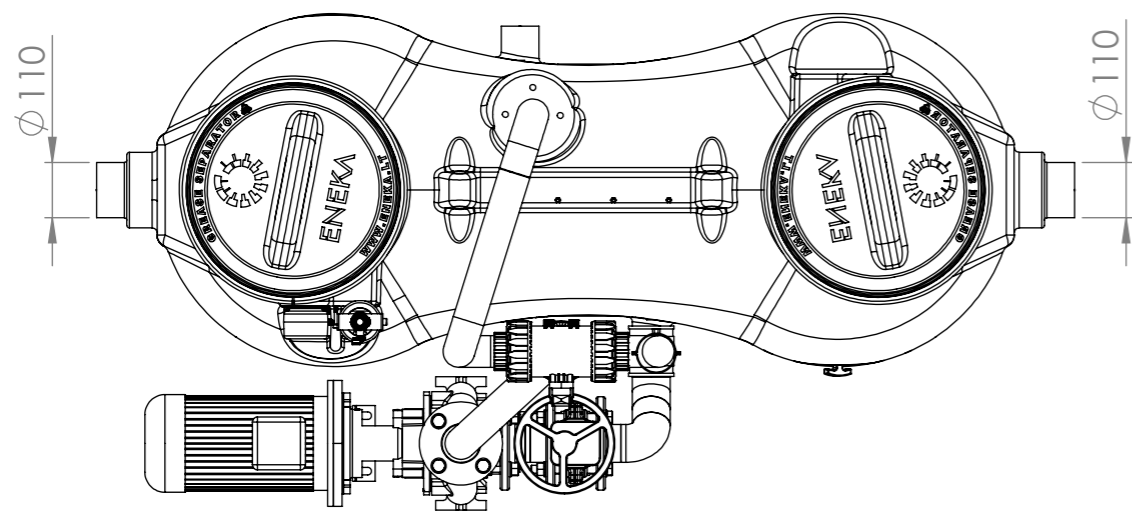

Product Greasly	Name Greasly 2A Pump-M	Scale 1:15
Design by V.Laucius	Checked by E.Mozuraitis	Approved by E.Kuodis
 UAB ENEKA Vandziogalos g. 94 LT-47467 Kaunas, Lithuania tel. +37037377441, faks.+37037377907 www.eneka.lt, info@eneka.lt		Construction site - Drawing type Customer drawing Drawing no. - Date 9/21/2021 Lang. en Sheet 1