

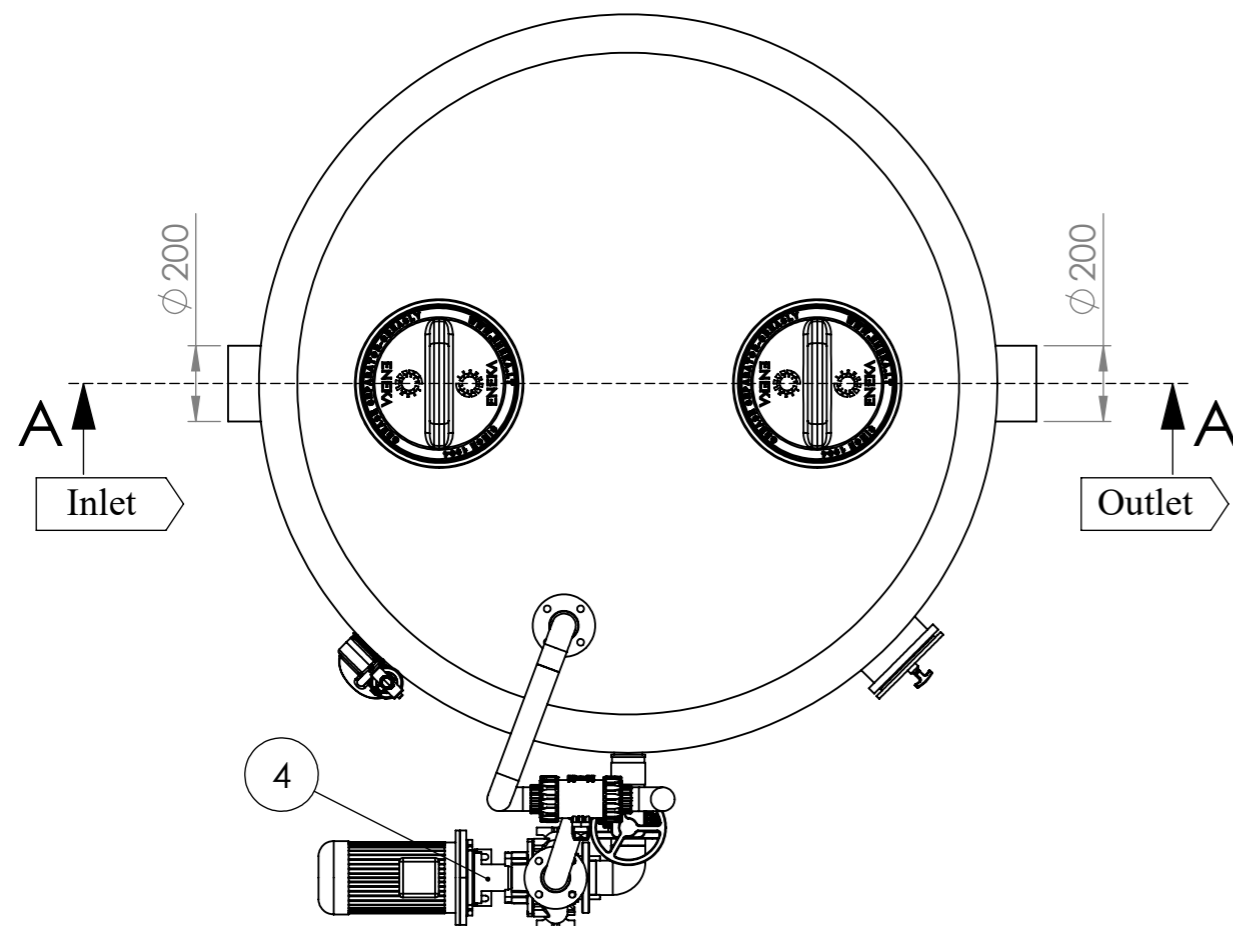

SECTION A-A
SCALE 1 : 20



1	Lids	
2	Inspection window	
3	Water refilling unit	
4	Disposal pump and mixing unit	
5	Sludge trap	1500 l
6	Grease separation chamber	1800 l
7	Storage capacity for grease	600 l
Nominal flow rate		15 l/s
Total capacity		3300 l

Product Greasly	Name Grease separator Greasly 15A Pump-M	Scale 1:20
Design by V.Laucius	Checked by E.Mozuraitis	Approved by E.Kuodis
 UAB ENEKA Vandziogalos g. 94 LT-47467 Kaunas, Lithuania tel. +37037377441, faks.+37037377907 www.eneka.lt, info@eneka.lt		Drawing type Customer drawing Drawing no. - Date 3/25/2022
Construction site -		Lang. Sheet en 1