

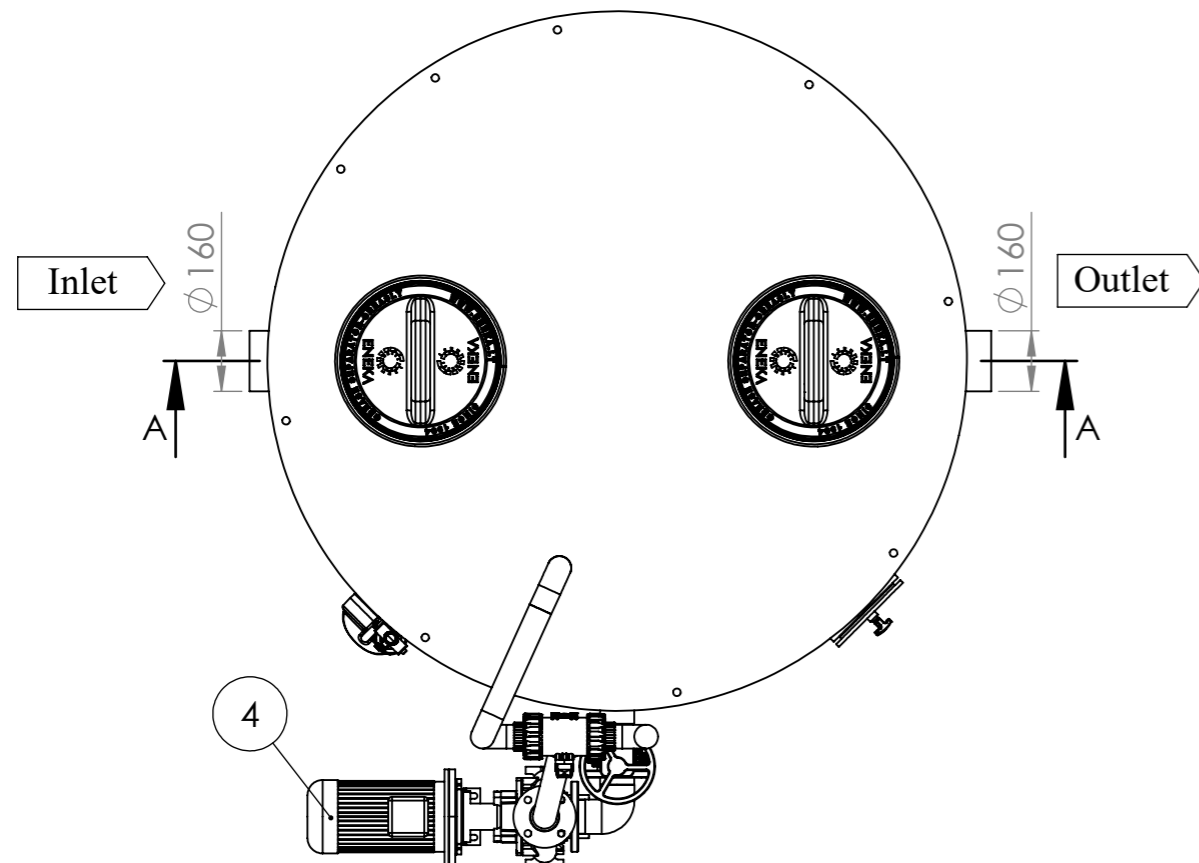

SECTION A-A
SCALE 1 : 20



1	Lid	
2	Inspection window	
3	Refilling unit	
4	Disposal pump and mixing unit	
5	Sludge trap	1000 l
6	Grease separation chamber	1610 l
7	Storage capacity for grease	400 l
Nominal flow rate		10 l/s
Total capacity		2610 l

Product Greasly	Name Grease separator Greasly 10A	Scale 1:20
Design by V.Laucius	Checked by E.Mozuraitis	Approved by E.Kuodis
 UAB ENEKA Vandziogalos g. 94 LT-47467 Kaunas, Lithuania tel. +37037377441, faks. +37037377907 www.eneka.lt, info@eneka.lt		Construction site - Drawing no. - Date 10/22/2021
		Drawing type Customer drawing Lang. en Sheet 1