

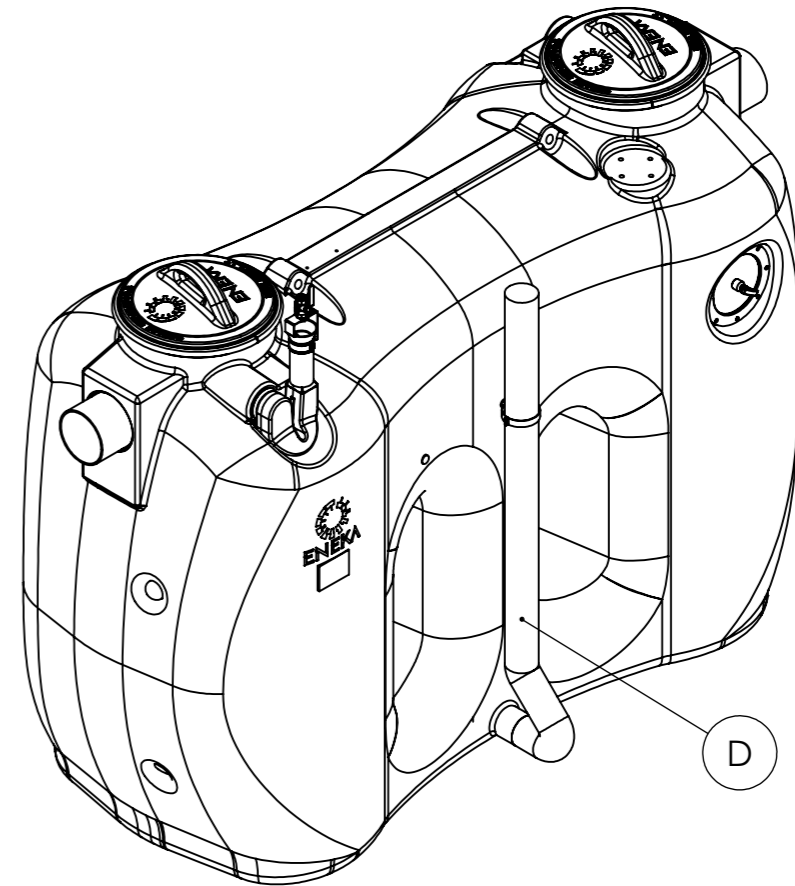

Position	Name	Quantity
A	Greasly 10A body	1
B	Lid with locking ring and gasket	2
C	Inspection window	1
D	Extraction pipe	1
E	Manual water filling unit	1
Greasly 10A Base technical characteristics		
	Flow rate	10 l/s
	Total volume	2076 l
	Grease volume	400 l
	Separator volume	1076 l
	Sludge trap volume	1000 l
	Weight	331 kg



Product Greasly A	Name Greasly 10A PRIMA	Scale 1:20
Design by V.Laucius	Checked by E.Mozuraitis	Approved by E.Kuodis
 UAB ENEKA Vandziogalos g. 94 LT-47467 Kaunas, Lithuania tel. +37037377441, faks. +37037377907 www.eneka.lt, info@eneka.lt		Drawing type Customer drawing Drawing no. - Date 6/7/2022
Construction site -		Lang. Sheet en 1